



PORT INDUSTRY

Product Brochure



LASE
Industrielle Lasertechnik GmbH



Rudolf-Diesel-Straße 111
46485 Wesel
Germany



TEL : +49 281 95990-0
FAX : +49 281 95990-111
www.lase-solutions.com

One step ahead with system applications by LASE!

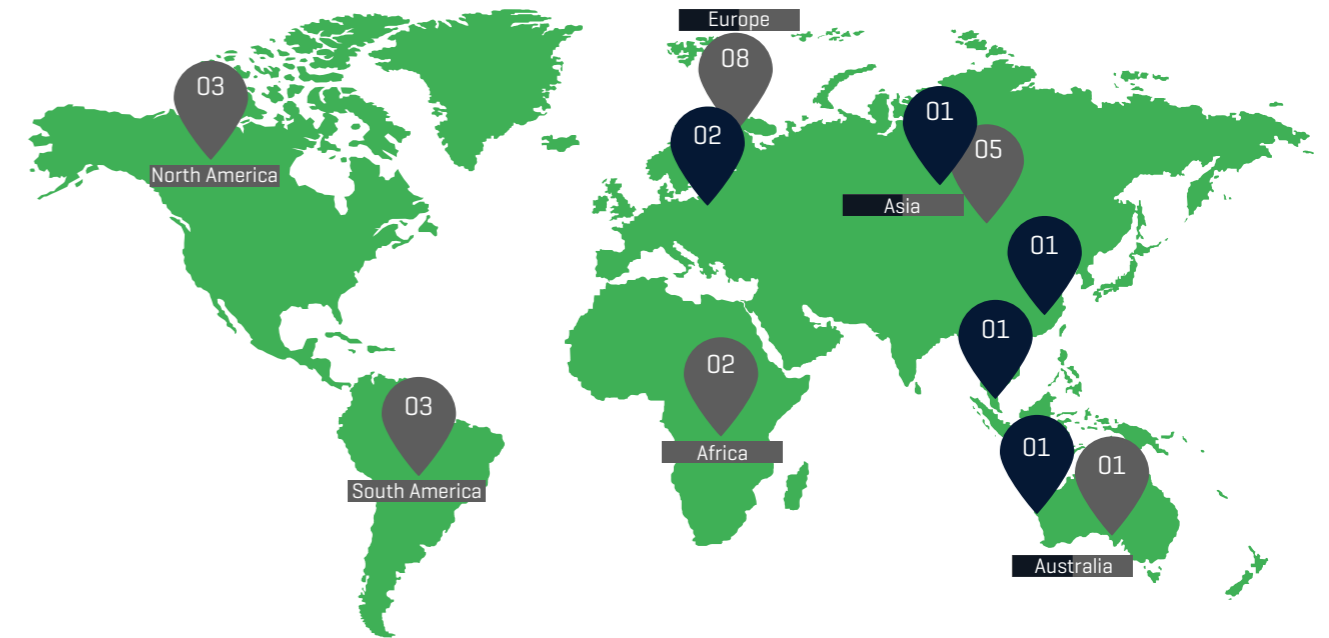

COOPERATION PARTNER OF LASE

OFFICES OF LASE

LASE WESEL [DE]

LASE Industrielle Lasertechnik GmbH
 Rudolf-Diesel-Str. 111
 46485 Wesel
 Germany
 Tel.: +49 281 959 90 0
 Fax: +49 281 959 90 111
 E-Mail: info@lase.de

LASE BREMEN [DE]

LASE Industrielle Lasertechnik GmbH
 Lise-Meitner-Str. 6
 28359 Bremen
 Germany
 Tel.: +49 421 66940-0
 Fax: +49 421 66940-20
 E-Mail: info@lase.de

LASE CHINA

LASE Industrial Laser Technology GmbH
 Shanghai Rep. Office
 Room 1004B, Xin Cheng Building
 No. 167, Jiang Ning Road
 200041, Shanghai
 Tel.: +86 [0] 21 6876 1250
 E-Mail: info@lase-cn.com

LASE AUSTRALIA

LASE Australia Pty. Ltd.
 Level 29, The Forrest Centre
 221 St Georges Terrace
 Perth WA 6000
 Australia
 Tel.: +61 [0] 8 9480 3759
 E-Mail: l.mohr@lase.de

LASE RUSSIA

000 LASE Russia
 Prospekt Pobedy 29
 RUS-398024 Lipetsk
 Russia
 Tel.: +7 [920] 516-18-18
 E-Mail: i.shilov.ext@lase.de

LASE SINGAPORE

LASE Singapore Pte. Ltd.
 16 Raffles Quay, 33-03
 Hong Leong Building
 Singapore [048581]
 Tel.: +49 174 184 7754
 E-Mail: m.vanwijck@lase.com.sg

LaseLCPS

Load Collision Prevention System

The application LaseLCPS - Load Collision Prevention System is a measurement system which works with 2D and/or 3D laser scanners mounted under the trolley. Depending on the specific version of this application, e.g. whether as LaseLCPS-2D, LaseLCPS-3D or even as combined LaseLCPS-3D-2D solution, this laser measurement system offers a variety of features to be implemented. All in all each version helps to prevent fatal accidents as well as collisions between load and stacks for RTGs and RMGs.



Load collision prevention and soft landing

In order to measure all relevant stacks a 3D profile scan in trolley direction will be processed before the first move. An additional 3D scan will be done after the trolley has passed the highest point of the stack in order to detect shadow areas.

A further collision prevention check by the dynamic surveillance cube has the function to avoid collisions between the empty spreader or container on the spreader and containers in the stacking area.

The position [cube center] is located in the middle of the spreader's lower edge. The expansion of the cube is depending on the adjusted length of the spreader [20', 40', 45'], height of container on the spreader, moving direction and the velocity of trolley and hoist.

The specific LaseLCPS software application collects the scan data, does all needed calculations and sends the results to the machine PLC.

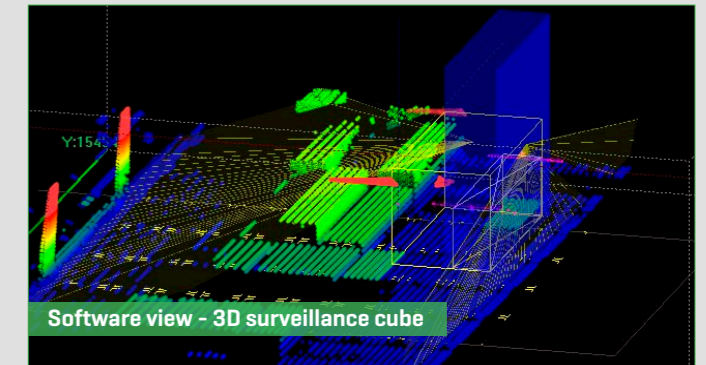
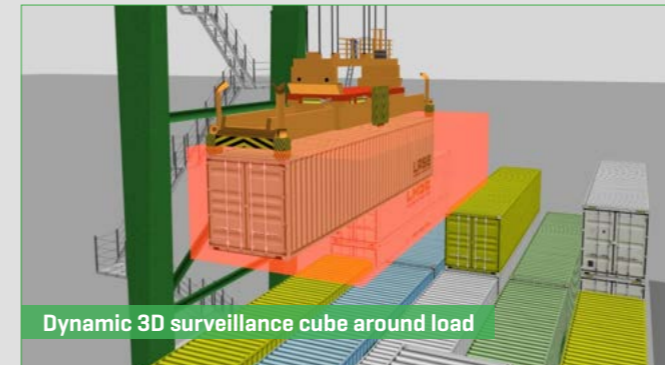

CUSTOMER BENEFITS AND FEATURES:

- ✔ Collision prevention between load and stack
- ✔ Applicable for RMGs and RTGs
- ✔ Avoids collisions with adjacent stacks in gantry direction
- ✔ Container soft landings and noise reduction
- ✔ Reduction of spreader wear
- ✔ Driver assistance
- ✔ Both 3D and/or 2D profile scan in trolley drive direction
- ✔ Reduction of container damage claims
- ✔ Stack height information for path optimisation

LaseLCPS-STs

Load Collision Prevention System

The solution LaseLCPS-STs - Load Collision Prevention System -STs is designed to ensure a collision prevention between load and container on vessels. The use of robust and state-of-the-art laser technology has the objective to diminish the risk of accidents while STS spreader operations. These are caused by human error when the operator does not hoist the spreader to a sufficient height to clear the highest container stacks.



Vessel profile measurement to prevent collisions

This measurement system consists of two LASE 2000D laser scanners (3D version with LASE 3000D laser scanners) which are mounted under the crane trolley. The specific software application collects the scan data, does all necessary calculations and sends the results to the PLC.

The laser scanners „look“ downwards with a scan plane across two bays. When the trolley starts driving over the vessel, the measurement system generates a 2D-profile (resp. 3D-) of the stacks within the bays. Additionally the spreader is in the view of the scanners and will be tracked. By comparing the actual load position (spreader with/without container load) with the profile of the stacks, a collision prevention is ensured.

The LaseLCPS-STs measurement system is primarily designed for STS crane operations and serves both to increase the safety and an efficient workflow in container handling.

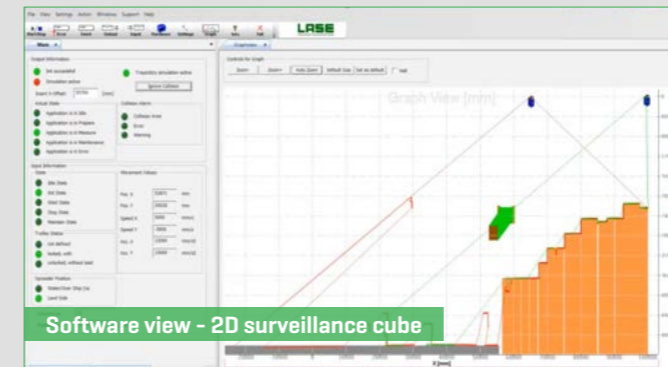

CUSTOMER BENEFITS AND FEATURES:

- ✔ 2D and/or 3D container profiling
- ✔ Detection of ship's longitudinal displacement
- ✔ Cell guide detection for fast approach
- ✔ Collision prevention between spreader and stacks
- ✔ Detection of adjacent objects like catwalks, ship cranes etc.
- ✔ Gentle container handling through soft landings
- ✔ Stack topography verification
- ✔ Less spreader wear and noise reduction
- ✔ Driver assistance

LaseAYC

Automatic Yard Crane

The application LaseAYC - Automatic Yard Crane is built to ensure a fully automated container handling in ASC stacking yards and supports semi-automatic truck handling in transfer areas. All its features allow an accelerated and fully automatic container handling as well as gentle treatment of materials through highly accurate soft landings on the trailers.



Scanner position at the crane driver cabin

Fully automated container handling and soft landing

The measurement system consists of two 3D laser scanners from the **LASE 3000D-Series**. Both 3D-Units are installed at a distance of approximately 2,9 metres on the trolley of an automatic stacking crane in order to measure containers, trailers or AGVs three-dimensionally.

This measurement system for automated container handling and the operation in ASC yards can be divided into four functions.

Firstly it recognises the top edges of the container in order to perform highly accurate pick-and-drop tasks for the landing of loaded or empty spreaders. Then it also detects misplaced containers within the clearance zone.

Furthermore it is able to detect the gap between two twenty-foot containers on terminal chassis before the pick-up operation. Recently the application **LaseAYC** undertakes a position verification after dropping a container in its cell.

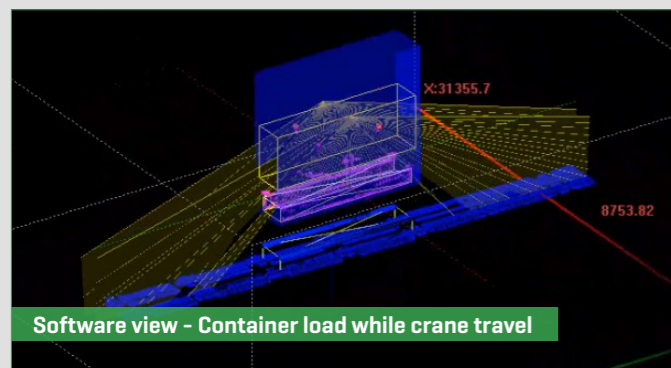

Software view - Container load while crane travel

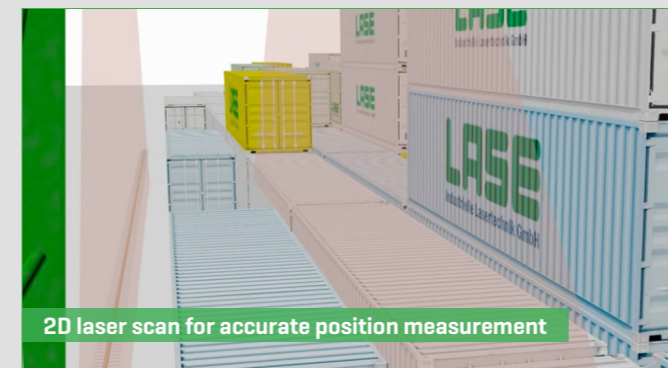

2D laser scan for accurate position measurement

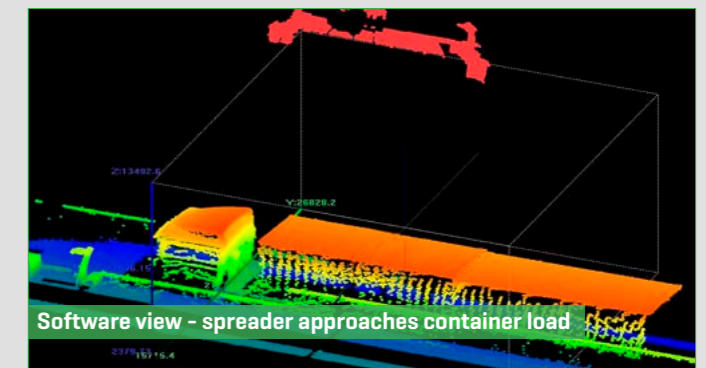

Software view - spreader approaches container load

CUSTOMER BENEFITS AND FEATURES:

- ✔ Container position and skew measurement for accurate picking and stacking
- ✔ Collision free lowering of spreader/load into the slot
- ✔ Collision prevention during trolley travel in the operation bay and in adjacent bays
- ✔ Gentle container handling by soft landings and less spreader wear
- ✔ Stack verification (aligning stack database with present layout)
- ✔ High precision measurement system
- ✔ Position measurement of trucks, trailers, AGVs and containers in transfer areas
- ✔ Also applicable for ASCs (aRMGs) and aRTGs

LaseBCP

Boom Collision Prevention



The application LaseBCP Boom Collision Prevention is a two-dimensional laser measurement system which observes the area around the boom of quay cranes during gantry travel. In case of detecting an obstacle on the vessel like e.g. bridge, radio antennas etc., a signal is provided to the crane control PLC in order to slow down or stop the crane movement before any collision can occur. The system is built especially for the use at STS vessel operations and prevents significant damages, crane down-times and particularly dangerous accidents.



2D laser scanner mounted at water-sided boom end

Smart obstacle detection under STS crane booms

The system LaseBCP consists of one 2D laser scanner from the LASE 2000D series, which is installed at the water-sided end of the STS crane boom. The laser scanner builds a horizontal scan plane under the crane boom along the lower side of the girder whose scan area is parametrized in terms of three graduated surveillance areas.

When the STS crane travels in gantry mode and an obstacle on the vessel approaches the surveillance areas a signal is generated and transferred to the crane PLC. The surveillance areas are divided into three different zones (blue, yellow, red) and according to the position of an obstacle inside the zones, the PLC evaluates the situation in order to slow down (yellow) or to stop (red) the gantry movement of the crane.

The main advantage of this system is the smart handling where detected objects are analyzed by their lifetime and spatial expansion. If both exceed pre-defined threshold values, the object is indicated and stored. This ensures a reliable system performance and avoids false alarm by e.g. birds, rain drops or snow flakes.



General max. scan area before parametrization



Scan plane divided into three surveillance areas

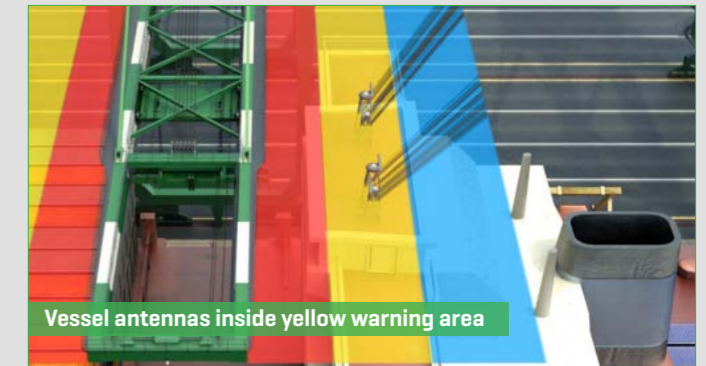

Vessel antennas inside yellow warning area

CUSTOMER BENEFITS AND FEATURES:

- ✔ 2D measurement system with state-of-the-art laser technology
- ✔ Exact and reliable boom collision prevention by smart obstacle detection
- ✔ Individually definable surveillance areas around crane boom
- ✔ Lifetime and spatial expansion analysis to avoid false alarms
- ✔ Immediate alarm signal to PLC stops gantry travel in the event of collision detection
- ✔ Ensures retro-fitting of existing quayside cranes
- ✔ Prevention of significant damages, crane down-times and injuries

LaseUCD

Unremoved Cone Detection



The application LaseUCD - Unremoved Cone Detection is a two-dimensional laser measurement system which detects whether container cones (twistlocks) are still connected to the container while being lifted up from a terminal truck chassis by RMG or RTG cranes. In case of the detection of an unremoved cone the application software sends an alarm signal to the PLC in order to stop the crane hoist move. The system is built especially for the use in automated and remote controlled container yards and prevents expensive damages and lethal accidents.

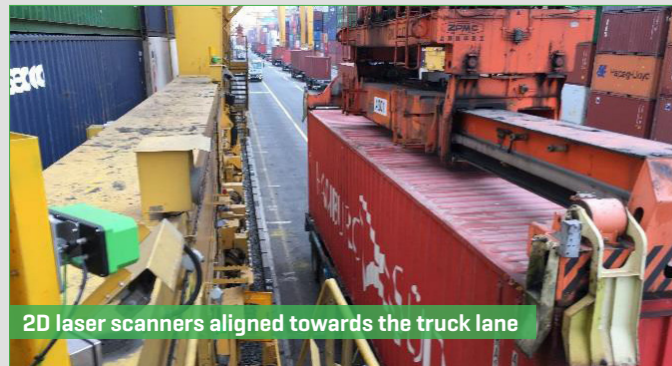

2D laser scanners aligned towards the truck lane

Accurate detection of unremoved container cones

This measurement system consists of two 2D laser scanners from the LASE 2000D series, which are installed at the sill beam of a yard crane in a height of approx. five meters above the truck lanes. Both 2D laser scanners build a horizontal scan plane in direction to the truck lane.

When a container is picked from the truck chassis by the crane it passes the scan plane where the profile of the container is scanned. The scan data are processed in the LaseUCD application software, which generates a 3D point cloud of the container. If an obstacle underneath the container protrudes from the container, it indicates that a cone is still connected. In this case the application software sends an alarm signal to the PLC in order to stop the crane hoist move.

The LaseUCD system is designed for RMG and RTG cranes and to increase the safety as well as to avoid damages on the container(s) and the crane. Additionally the system also detects open doors of containers during the same measurement process.

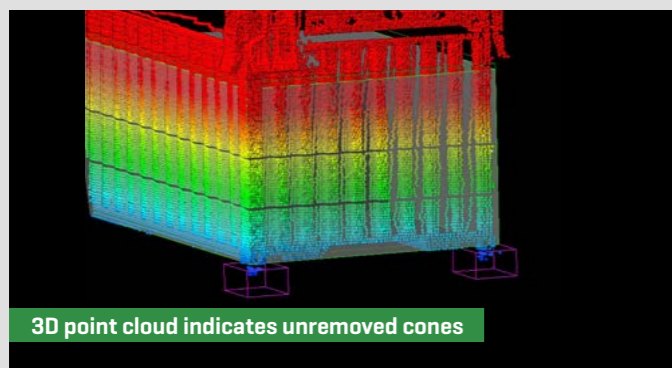

3D point cloud indicates unremoved cones



Horizontal 2D scan planes detect lifted containers

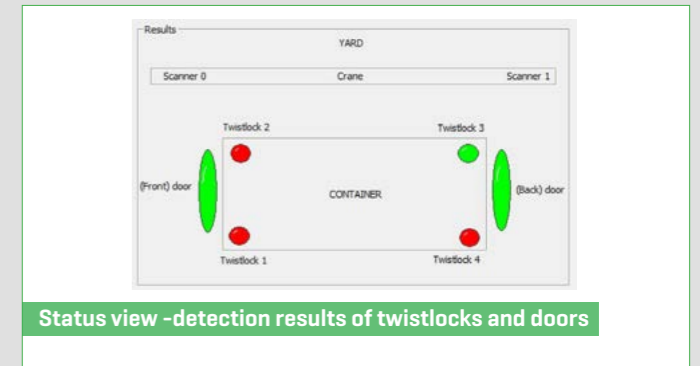

Status view -detection results of twistlocks and doors

CUSTOMER BENEFITS AND FEATURES:

- ✔ 2D measurement of containers for cones/twistlocks and open doors
- ✔ Exact and reliable cone detection by state-of-the-art laser technology
- ✔ Independent from skew, tilt or trim angles of the container
- ✔ Useable for all container types (20, 40 and 45ft)
- ✔ Supports fully automated container handling
- ✔ Immediate alarm signal to PLC stops crane hoist move
- ✔ Usable for ARMG, RMG, ARTG and RTG crane types

LaseGCP

Gantry Collision Prevention



The LaseGCP - Gantry Collision Prevention system is a driver assistance system that helps crane operators to avoid collisions and increase system availability. The system can be used with two or four 2D laser scanners mounted at the gantry heading in both driving directions. The scan planes are projected horizontally over the ground.

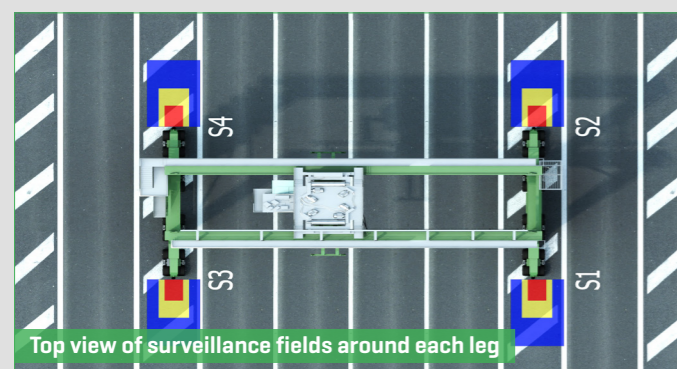

Reliable collision prevention in crane gantry travel

The laser measurement system consists of two or four 2D laser scanners from the LASE 2000D Series. Mounted at the gantry in a height of approx. 1 - 1,5 m, the scan planes are projected parallelly to the ground. The data from the laser scanner are send to a central controller device for data evaluation and the detection of dangerous situations. Thus in the control system dynamic surveillance fields are generated - analogue to the crane speed. This means that the scan fields are small at low speeds and will increase with the gantry speed. The fields cover the width of the gantry (incl. stairs which might be on the side of the crane). The system works with three detection fields. The biggest and most external one is for the building of candidates - the "candidates field".

These candidates are serious objects with a certain size and lifetime that should be protected when approaching the warning or the alarm field. This method avoids false alarms by randomly occurring objects, like for example under conditions with snow-fall or bird-fly. When the object approaches the smaller "warning field", then the system reacts and sends a warning signal to the crane driver and starts reducing the gantry speed. When the next field, the "alarm field", will be injured, then an immediate emergency stop will be initialised.

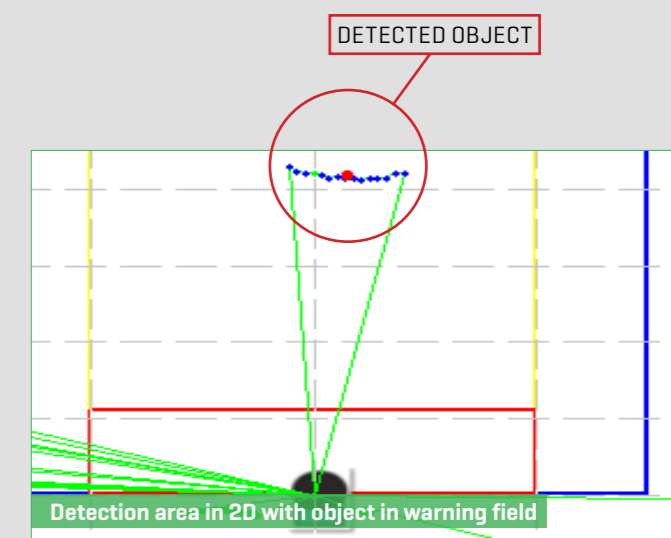
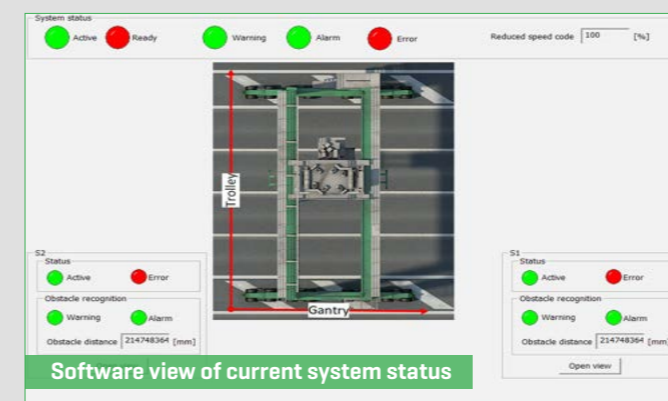

CUSTOMER BENEFITS AND FEATURES:

- ✔ Prevention of dangerous situations and thereby increasing the level of safety
- ✔ Cost savings by collision prevention and avoiding repair costs
- ✔ Increased system availability due to decreased crane downtimes
- ✔ Modular system construction - two or four sensors can be used
- ✔ High reliability against environmental influences - no false alarms
- ✔ Trustable product with high acceptance by crane drivers
- ✔ Crane driver can concentrate on the operation

LaseSPC

Straddle [Carrier] Positioning Crane



The solution LaseSPC - Straddle [Carrier] Positioning Crane accelerates container handling operations using straddle carriers in ship-to-shore [STS] operation areas. The measurement system by LASE is applicable for an exact SC positioning and is applicable for multi-lane operations with up to two Straddle Carriers simultaneously.

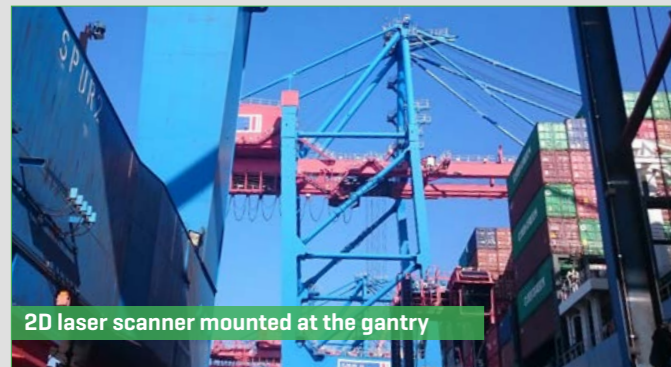

2D laser scanner mounted at the gantry

Precise positioning of Straddle Carriers

The application LaseSPC - Straddle [Carrier] Positioning Crane is a 2D measurement system consisting of two 2D laser scanners mounted each at the water- and the landsided gantry .

The straddle carriers are equipped with reference markers on all four legs and after the straddle carrier is under or approaching the crane, the measurement system detects them and calculates the exact position of the straddle carrier [SC].

With the use of LED displays, the straddle carrier driver receives a feedback about his relative position to the crane centre and the final target position. Possible corrections of the position will be shown as numeric displacement information in order to move forwards or backwards.

Furthermore, the information of the straddle carrier will be hosted to the crane control system in order to prevent the hoist lowering into the lane where the straddle carrier is. The system offers an exact positioning of straddle carriers and is even applicable for multi-lane operations, whereby two straddle carriers can measure at the same time.



LED display assistance for alignment position

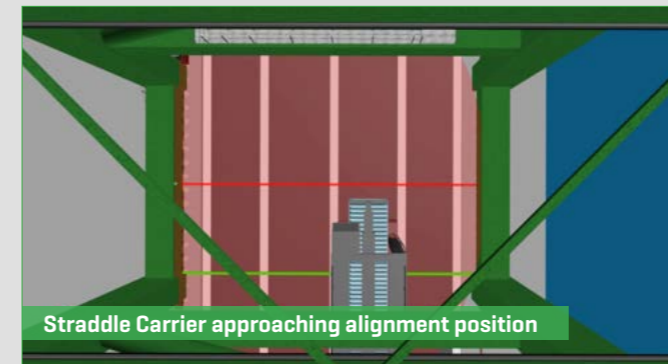

Straddle Carrier approaching alignment position

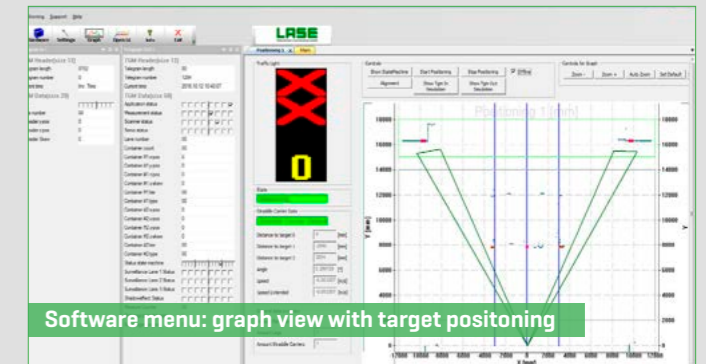

Software menu: graph view with target positioning

CUSTOMER BENEFITS AND FEATURES:

- ✔ Highly exact positioning of Straddle Carriers under STS cranes
- ✔ Applicable for multi-lane operations (max. 2x Straddle Carriers at the same time)
- ✔ Accelerates the handover of the load
- ✔ Retrofittable
- ✔ Easy feedback over LED display to reach target position
- ✔ Intuitive commissioning and maintenance tools
- ✔ Accurate and durable laser measurement devices

LaseTPC

Truck Positioning Crane



The solution LaseTPC - Truck Positioning Crane is designed to take over a fully automated truck positioning under STS cranes, but can also be applied at ARMG, RMG and RTG cranes. The use of robust and state-of-the-art laser technology has the aim to reduce personnel in such danger zones while STS spreader operations. Furthermore the system accelerates container handling operations both at the water- and land-sided loading areas.



3D laser scanner mounted at the girder above lane

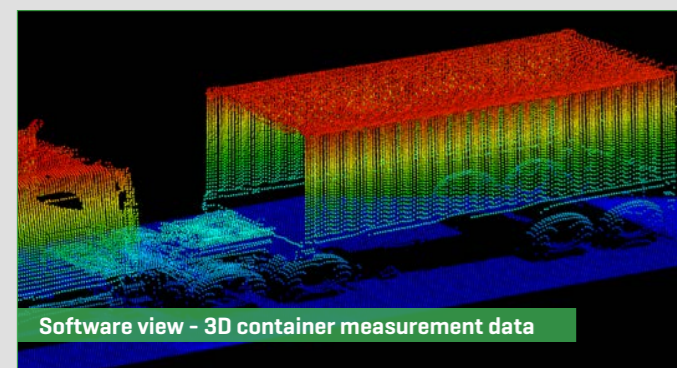

Software view - 3D container measurement data

Accurate truck positioning under STS cranes

This measurement system consists of one or two LASE 3000D laser scanners, which are installed on both sides of the cranes' transversal girder. The scenery in the portal is measured both 2- and 3-dimensionally now.

LaseTPC helps to determine the position of trucks, trailers, AGVs or containers on the vehicles as well as on the ground. This system is also particularly important for double hoist/spreader operations - otherwise the crane driver needs considerably more time to get the spreader on the container. By the assistance of a traffic light system truck drivers easily can reach their final un-/loading position.

The LaseTPC (Truck Positioning Crane) measurement system is primarily designed for STS container cranes and serves both to increase the safety of the dock workers and an efficient workflow in container handling. Basically the system can also be applied for other crane types like ARMG, RMG and RTG, which need the exact position of vehicles.



Scan plane swiveling over loaded truck in lane



Software view - Truck positioning in two lanes

CUSTOMER BENEFITS AND FEATURES:

- ✔ 2D position measurement of containers, trailers or AGVs
- ✔ Exact truck positioning by modern laser technology
- ✔ Accelerated crane operations and productivity
- ✔ Useable for single or double spreader operations
- ✔ Supports fully automated container handling
- ✔ More safety by reduced labor activity below the crane
- ✔ Savings in labor costs
- ✔ Usable for STS, ARMG, RMG and RTG crane types

LaseAVP

Automatic Vehicle Position



The measurement system LaseAVP -Automatic Positioning Vehicle is designed for STS-Crane operations for an efficient workflow in container handling while loading and unloading operations of vessels. The application is able to position AGVs for all common container types, e.g. 20ft, 40ft and 45ft and can also be utilised for twin-mode spreader operations under STS-Cranes.



Spreader approaches load after position verification

Precise AGV position verification

A 3D laser scanner from the LASE 3000D-C2-11x Series is mounted at the portal girder centrally above the lanes, whose projected scan plane detects AGVs in the chosen operation lane.

When an AGV drives to the crane position the laser-based measurement system verifies, if an AGV is present at this position or not. In for example semi-automatic operations, an AGV receives a position where it has to drive to carry or fetch a container [or two 20ft containers in twin-mode operation].

After arriving, the crane PLC triggers the LASE system to verify the exact position and to calculate the skew of a free slot or load on the AGV. In this case the 3D laser scanner swivels above the demanded lane.

For the further process of loading or unloading the system measures, if the AGV stands in a centric position under the crane trolley. The values for a centric position have a specific tolerance range and allow non-stop loading operations.

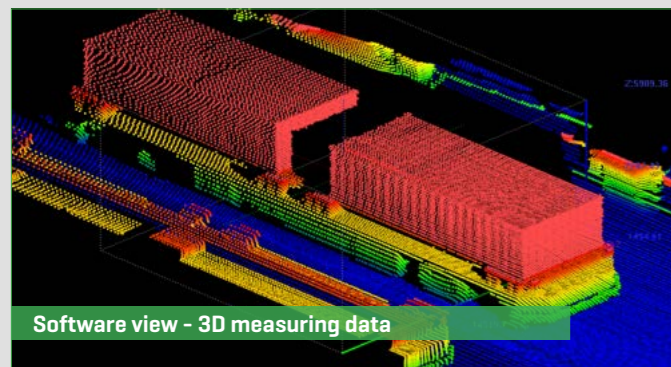

Software view - 3D measuring data



Scan plane by 3D laser scanner above lane

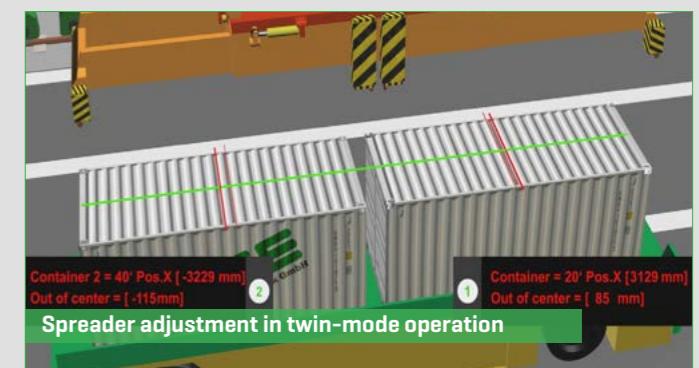

Spreader adjustment in twin-mode operation

CUSTOMER BENEFITS AND FEATURES:

- ✔ 3D position verification of container and AGV
- ✔ Exact AGV positioning in up to 3 lanes
- ✔ Supports fully automated container handling
- ✔ Also useable for twin-mode spreader operations
- ✔ Applicable for all container types [20ft, 40ft and 45ft]
- ✔ Accelerated crane operations and productivity

LaseTLP

Truck Lifting Prevention



The application LaseTLP - Truck Lifting Prevention ensures a lifting prevention of truck-trailers during the hoist process caused by locked or jammed twistlocks. This innovative solution is built to avoid severe accidents during truck unloading operations by defective or locked twistlock latches. The measurement system is applied for RTG, RMG and ARMG cranes and prevents that trucks/trailers are lifted into the air.

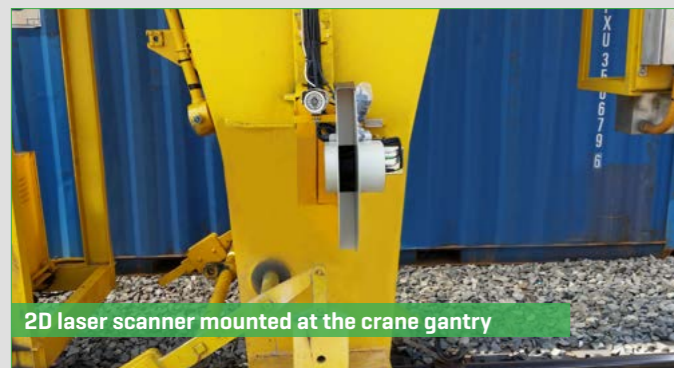

2D laser scanner mounted at the crane gantry

Reliable and accurate truck lifting prevention

Sometimes it might occur that truck-trailers are lifted up by the crane hoist when one or more twistlocks are still locked or not completely loosened. In order to prevent such accidents a system is required to detect the lifting of the trailer early enough.

The measurement system consists of one (or two) LASE 2000D laser scanners which are mounted at the gantry of the crane with vertical scan planes aligned towards the truck lane. The scanner(s) track the objects and compare the position of the lifted container and the trailer structure during the whole lifting process.

In case that both objects (container and trailer) move upwards due to one or more locked twistlocks, the system generates an immediate alarm signal to stop the hoist movement before any damage or injury can occur. Furthermore the system is both very sensitive (reacts fast in case of lifting) and eliminates the generation of false alarms - both make the application to a reliable and highly accepted system by port operators.

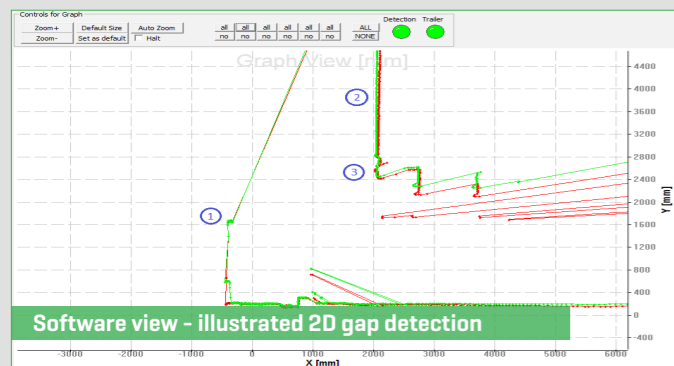

Software view - illustrated 2D gap detection



Vertical scan plane to prevent truck lifting cases

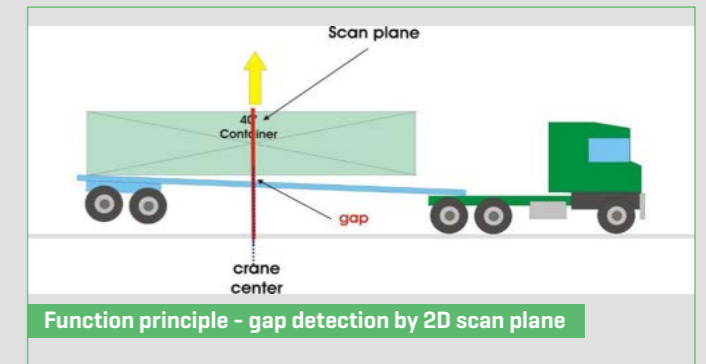

Function principle - gap detection by 2D scan plane

CUSTOMER BENEFITS AND FEATURES:

- ✔ High system reliability without false alarms
- ✔ Applicable for all truck-trailer types
- ✔ Accurate tracking of object position (trailer and container)
- ✔ Prevention of severe accidents
- ✔ Time-efficient process optimisation
- ✔ Damage avoidance at container and chassis
- ✔ Reduction of material wear for spreaders and machine parts
- ✔ Easily adaptable also for retrofitting



LASE 3000D-Series

The high performance laser scanners out of the **LASE 3000D-Series** are particularly designed for industrial applications with the background to create a robust, modular and economic 3D-Laser measurement system.

A 3D laser scanner consists of a mechanical swivel platform with an assembled 2-dimensional laser scanner for measuring tasks. The platform has a swivel table, which can be turned by a servo motor for the operation in swivel mode. A high resolution encoder is integrated within the servo motor and measures the exact turning angle of the swivel table simultaneously. By the assignment of 2D laser scan data with the encoder values [turning angle], the contactless reception of 3-dimensional measuring data can be handled as well as high precision 3D profile measurements are produced.

With the large measuring range, unrestricted scan angle and high angular resolution the 3D laser scanners from the LASE 3000D-Series are suitable for a huge variety of industries and applications such as:

- ✔ Measurement of dimensions, profiles or levels of objects and environments
- ✔ Object positioning
- ✔ Container recognition/measurement
- ✔ Object protection
- ✔ Bulk material measurement at heaps, piles, bunkers or trucks

COMMON BENEFITS AND FEATURES

PERFORMANCE DATA

- ✔ Contactless long range 3D profile measurement
- ✔ Measuring range up to 250 m on natural targets
- ✔ Scan range up to 360° [dependent on scanner type]
- ✔ Swivel range up to ± 100°
- ✔ Swivel velocity controlled by specific application
- ✔ High accuracy, high resolution and fast measuring rate
- ✔ Rugged design to IP 65

BENEFITS

- ✔ High accuracy in comparison to other technologies
- ✔ Surface material/colour without any effect on accuracy
- ✔ Measurement range without any effect on accuracy
- ✔ Minor spot diameter
- ✔ Plainly better edge detection
- ✔ More accurate size, position and volume measurement

Overview

Compact and Standard Series

COMPACT SERIES

LASE 3000D-C1-11x and 22x

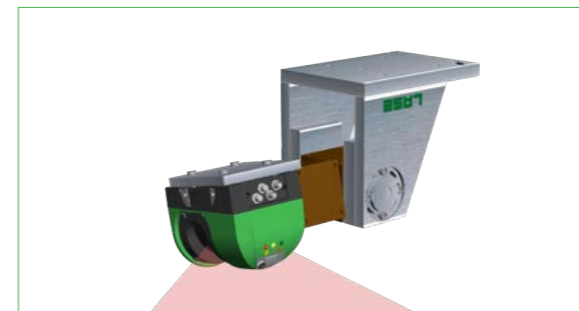

COMPACT SERIES

LASE 3000D-C3-22x

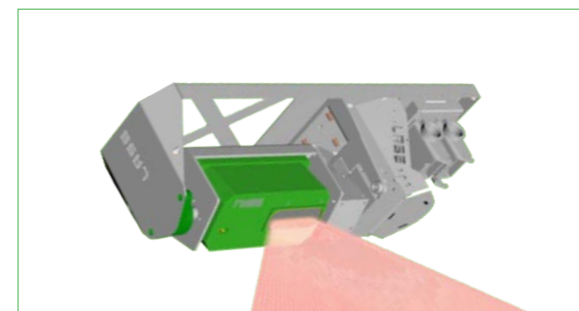

COMPACT SERIES

LASE 3000D-C2-11x

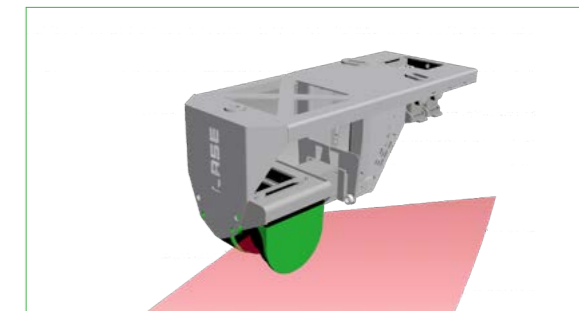

STANDARD SERIES

LASE 3000D-S-13x

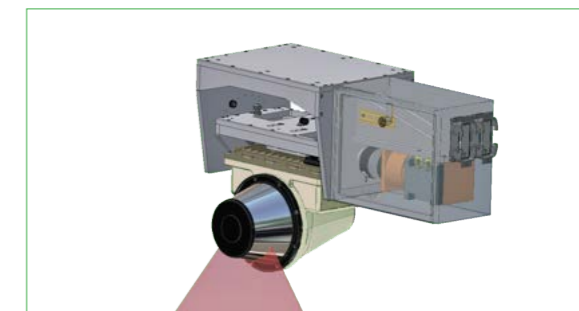

LASE - Competence, creativity and passion meet experience, innovation and quality.

Starting more than 25 years ago with ordinary one-dimensional distance measurements in heavy-industry environments, our portfolio of products emerged to highly complex software solutions mainly in the fields of safety and automation. Since the first day, all our products and developments meet the highest standards as well as demands in order to serve our customers in the best manner.

The combination of state-of-the-art laser devices and sophisticated software solutions can ensure the highest degree of functionality and satisfaction. Furthermore LASE puts a high emphasis on operator friendliness and system reliability.

Our large portfolio of solutions has been developed through the experience which we have gained by the close cooperation with our customers.

World-wide representations

LASE is represented worldwide through a well-established distributor network. Our distributors are our reliable partners - they are staying by your side and support you from consulting through to After-Sales-Service.

Their close proximity allows us to assure the best possible service for you. Our distributors are constantly educated by LASE through training, new product information and joint visits to customers to be your competent partner. However, if the experience of LASE is necessary - you can also get support by our application experts.

Belgium, Brazil, Bulgaria, Canada, Chile, China, Colombia, Finland, Guatemala, India, Iran, Italy, Mexico & Central America, Romania, Russia, South Africa, South Korea, Spain, Turkey, UK, USA

We have partners in

BE BETTER WITH LASE



WE ARE HERE FOR YOU

sales@lase.de



LASE
Industrielle Lasertechnik GmbH



Rudolf-Diesel-Straße 111
46485 Wesel
Germany



TEL : +49 281 95990-0
FAX : +49 281 95990-111
www.lase-solutions.com